

**QUIPP SELLS TWO (2) INSERTERS TO *AMERICAN COLOR GRAPHICS* AND LAUNCHES "REMANUFACTURED FEEDER PROGRAM" TO EXISTING SLS-1000® INSERTER USERS**

Quipp has received an order from *American Color Graphics* for two (2) Newstec High-Speed Inserters, two (2) Quipp Model 500 Wide Stackers, two (2) Quipp Viper  $\frac{3}{4}$  Wrappers with Powered Side Walls, Spares Parts and Installation Services.

One of the inserters will be a 16:2 machine and the other a 12:2 machine.

This complete system will be installed in their Dayton, NJ facility in the next few months.

As per Mr. Mike Kady, Quipp's President & CEO: "Quipp is proud of the partnership that we have been developing with *American Color Graphics* over the last few months. The first system we shipped to them was back at the beginning of the year, when we installed a Newstec High-Speed Inserter (16:2 machine) in their facility in Medina, OH."



**Above: High-Speed Inserters being manufactured in our facility in Miami, Florida**

**ATTENTION EXISTING SLS-1000® INSERTER USERS:  
QUIPP AND NEWSTEC NOW OFFER A COMPLETE "REMANUFACTURED  
FEEDER PROGRAM" FOR EXISTING SLS-1000® USERS**

**Quipp and Newstec now offer a complete "Remanufactured Feeder Program" and many other inserter parts for existing SLS-1000® inserter users.**

Customer can purchase the entire remanufactured feeder assembly including the following:

- **Drum Shaft Assembly**
- **Main Feeder Assembly**
- **Standard Feeder Operator Station Assembly**
- **New Electric Clutch Assembly**

Or purchase any of the above assemblies **with or with out exchange** (except the electric clutch).

Orders can be processed in 6-8 weeks. Customer is responsible for returning a useable core if exchange is included. Customer is responsible for all freight charges.

See description of work in the next 2 pages.



## Remanufactured SLS-1000® Standard Feeder Work Statement

### Drum Shaft Assembly

- **Replace**
  - Bearings
  - Bushings
  - Cam Followers
  - Rods and rod ends
  - Springs
  - Gears
  - Shafts
  - Inhibit latch and catch
  - Spring tubes and pivot blocks
  - Load levers
  - Grippers and seats
  - Reflectors
  - Hardware
  - *Optional: "Conversion to lubeless components"*

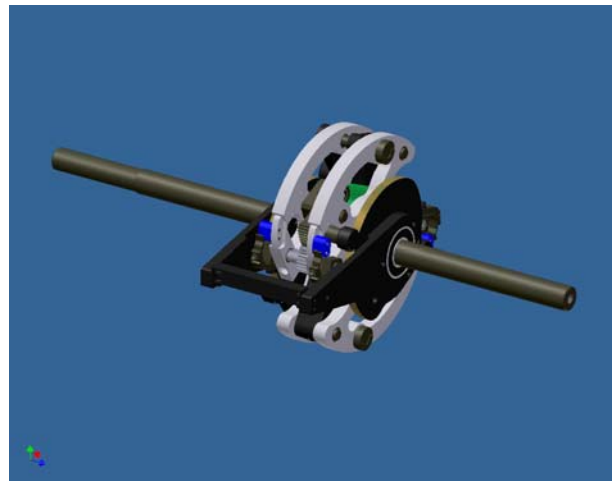

### Main Feeder Assembly

- **Replace**
  - Bearings
  - Bushings
  - Cam Followers
  - Rods and rod ends
  - Springs
  - Inhibit latch and catch
  - Rear pile lift
  - Needles
  - Suckers
  - Hardware
  - *Optional: "Conversion to lubeless components"*

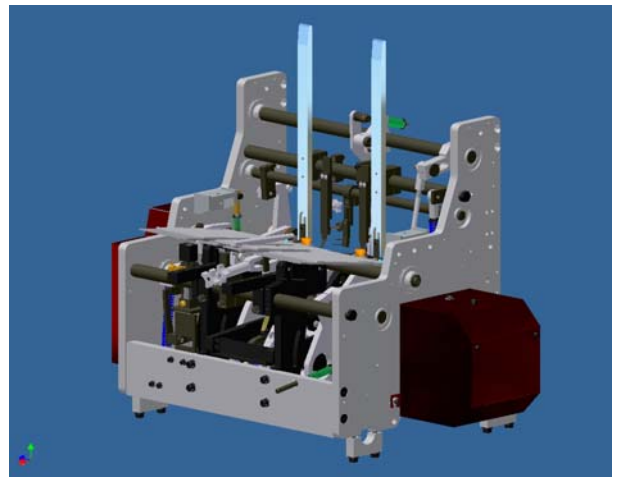

- **Clean, prep and refinish as required**
  - Frames
  - Guides
  - Shafts
  - Levers
  - Castings

- **Factory time and run-in test**

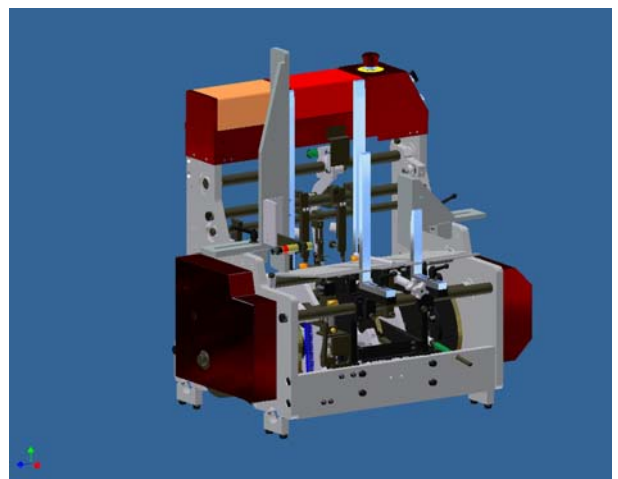

### Standard Feeder Operator Station Assembly

- Clean, prep and paint enclosure
- Test and insure functional operator station
- Replace defective parts as necessary

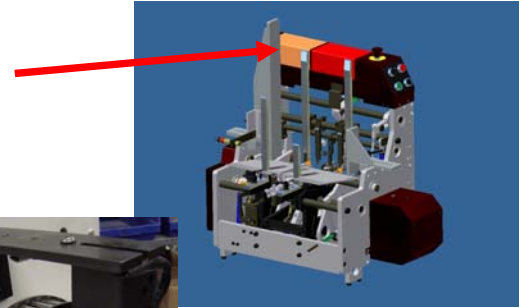

### New Electric Clutch Assembly

- Including clamp collar and quick connector



For additional information, pricing & availability on the Quipp-Newstec “*Remanufactured Feeder Program*” and other SLS-1000® Inserter Parts, please contact our experienced Parts Department today at:

Phone: 305-623-8700 ext. 348 or 339

1-800-258-1390 ext. 377

Fax: 305-623-0980

[parts@quipp.com](mailto:parts@quipp.com)



**QUIPP PARTICIPATES IN THE "COX NEWSPAPERS 2006 SUPPLIER APPRECIATION GOLF OUTING" IN DAYTON, OH.**



Scramble Winners with a respectable 9 under par (from left to right): Gary Grissom, Angel Arrabal, Joe Bella & Ken Carpenter.

**QUIPP, INC., THROUGH ITS SUBSIDIARIES,  
QUIPP SYSTEMS, INC. AND NEWSTEC, INC.  
OFFERS A COMPLETE LINE OF RELIABLE  
MAILROOM EQUIPMENT.**



**The Intelligent Post Press Solution**

[www.quipp.com](http://www.quipp.com)

[www.newstec.com](http://www.newstec.com)